

Electronic Dyno Sounder EDS



Artificial Lift

The Electronic Dyno Sounder is a digital instrument to acquire dynamometer and liquid level data. Power / current measurement, pressure buildup or transient data may also be collected for full well analysis and increase of oil and gas production.

Description

The Electronic Dyno Sounder is a digital instrument to acquire dynamometer and liquid level data. Power / current measurement, pressure buildup or transient data may also be collected for full well analysis and increase of oil and gas production. Main components of the EDS are the dynamometer DYN 17 and the acoustic liquid level instrument sonoecho™. Gear box torque, power factor and motor loading may be recorded using supplementary power / current clamps. The software allows the user to generate dynamometer and fluid level reports, including screen shots of graphs and data. All reports may be printed, saved as data files (e.g. csv, LAS) or transmitted electronically as Adobe pdf files.

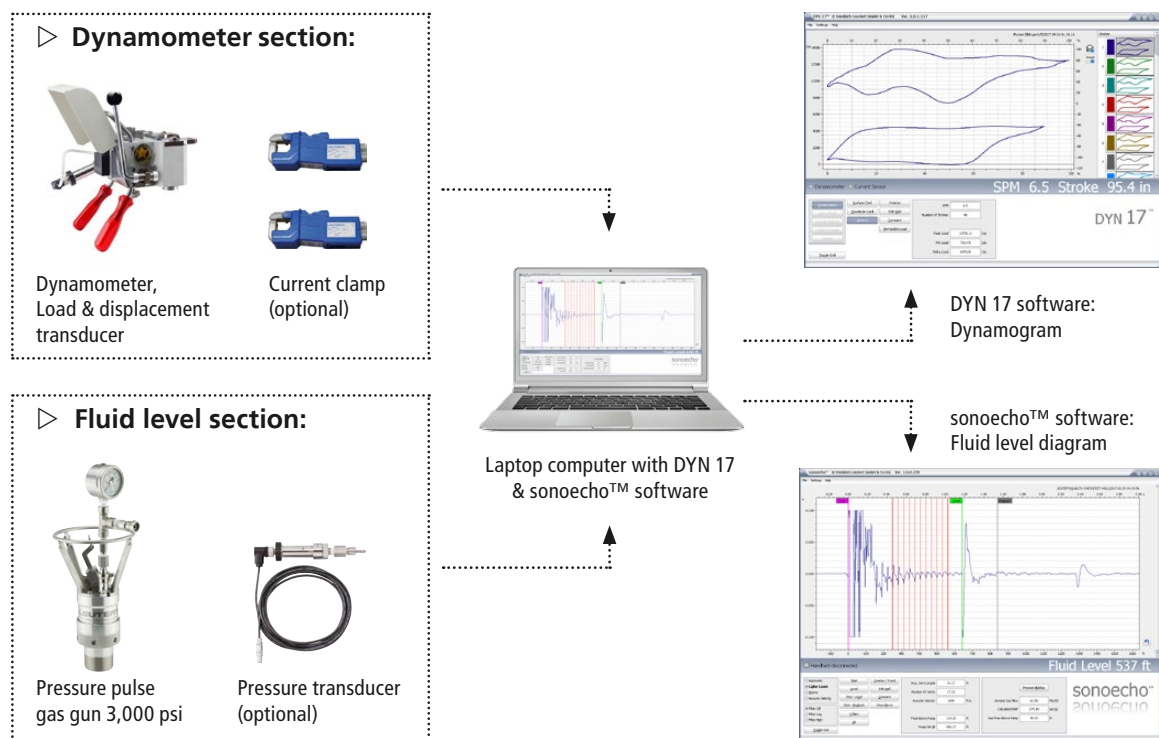

Dynamometer Test

The DYN 17 records the polished rod load (instantaneous load) throughout the working cycle of a deep well pump. It provides accurate information about pump efficiency and the production that may be expected from it. It allows recognizing the onset of pump failures, such as plunger or barrel wear and worn or sticking valves, prior to a production drop becoming apparent. If production drops, a dynamometer log will provide evidence quickly to diagnose the fault. Regular, dynamometer tests will draw attention to the inception of faults and, thus, reduce expensive servicing time and costly loss of production.

Unlike other systems measurements with the DYN 17 provide representative data as the pump jack does not have to be stopped to perform the dynamometer test and therefore the downhole conditions will not get disturbed. To achieve this each pumping unit to be logged will be equipped with a set of spacers (blue marked) fitted to the polished rod above the hanger bar between the two wire lines. Once fitted, the attachment gear remains as a permanent fixture to the pump and provides the unique advantage to instantly check the pump with the LEUTERT DYN 17.

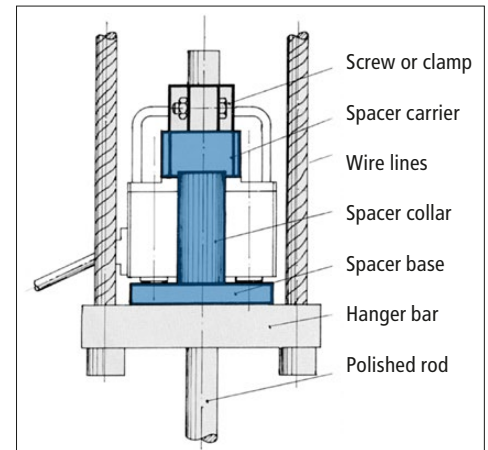

Installation of the spacers

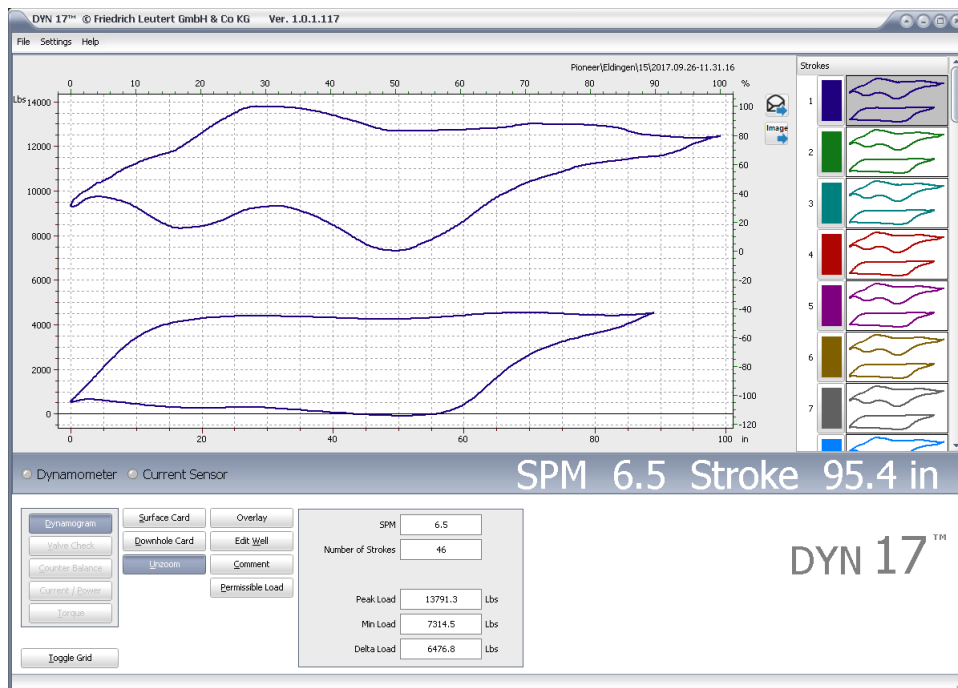

Recorded surface dynamometer card and calculated downhole card

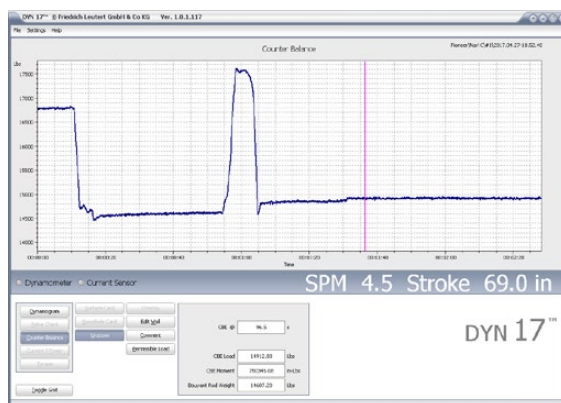

Counterbalance

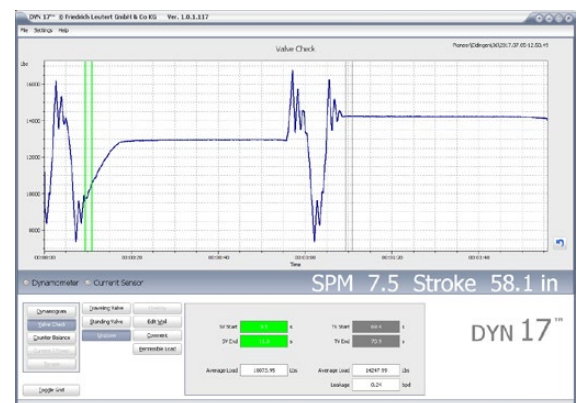

Valve check

Acoustic Liquid Level Test

The sonoecho™ is a precision instrument for determination of the fluid level in the casing of a pumping well. The Pressure Pulse Gas Gun of the sonoecho™ sends a gas pressure pulse down the annulus of the well. The pressure pulse reflects from each collar and the fluid as it travels down the well. The acquired liquid level data may be displayed on computer screen and analyzed with the windows based software that makes it easy to find, calculate, and print accurate fluid level data. In addition a casing pressure build-up test may be performed. As a result of this test the casing annulus gas flow is calculated and the gas free liquid level will be displayed.

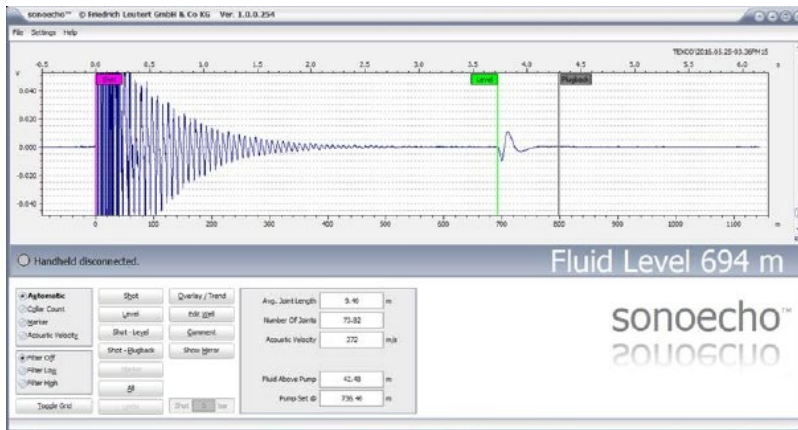
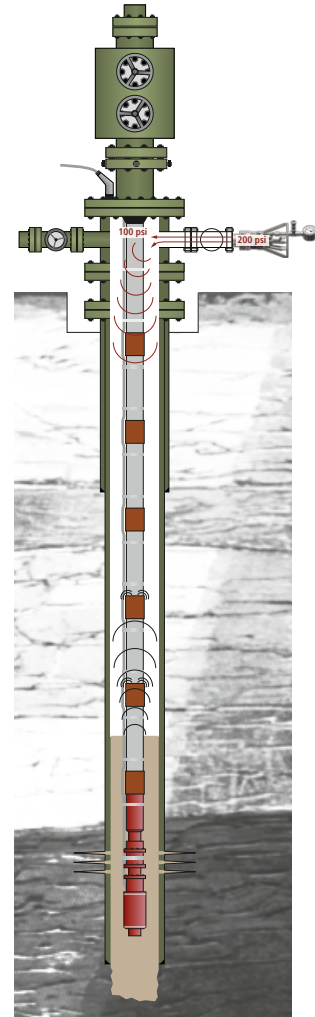

Acoustic liquid level test result

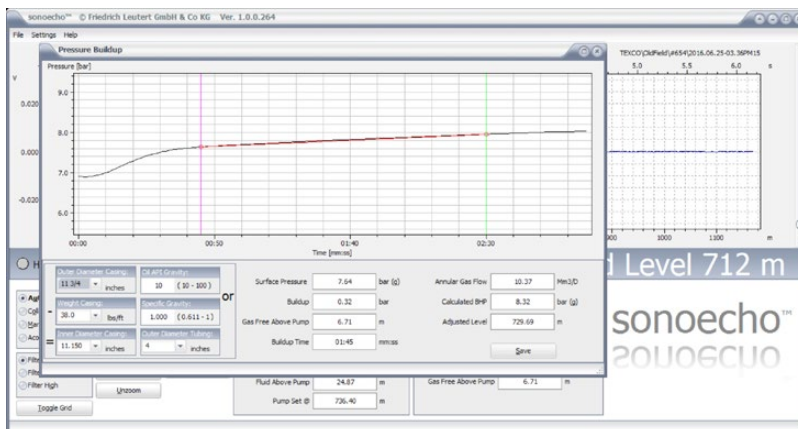

Pressure buildup test

Fluid level measurement
sonoecho™